

GARMENT SPECIFICATION SHEET

ESD CLEANROOM HOOD

PROTRACK CODE | V81

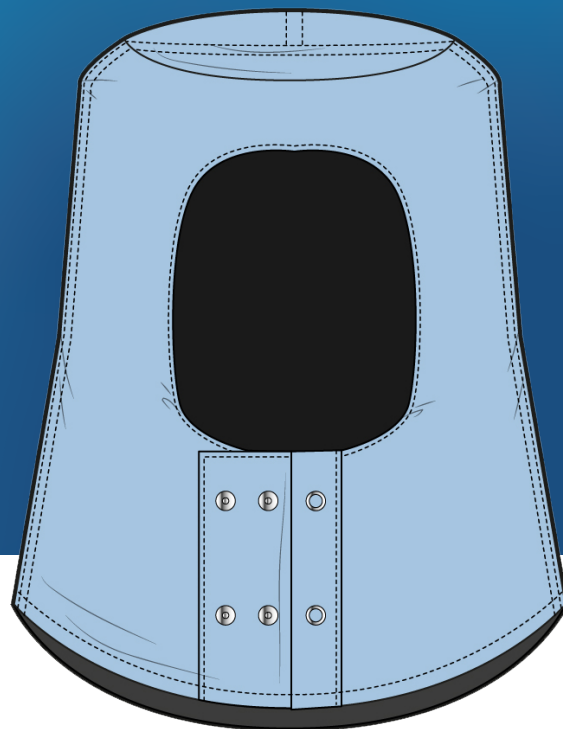

DESCRIPTION

Front fastening ESD Cleanroom hood with three position stud adjustment.

FEATURES

Stainless Steel Stud size adjustments;
Side seams and back side are constructed with integrated conductive tape which is lock stitched at the centre;
All panel edges are heat sealed.

FABRIC

Main - 98% polyester filament yarn / 2% anti-static grid
ESD Tape - 70% polyester / 30% carbon-nylon

WEIGHT

105gsm

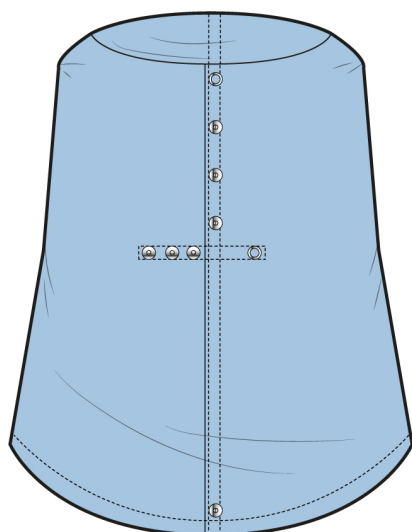

STD COLOUR COLOUR | PROTRACK CODE

 Std Light Blue / V81

NON STD COLOURS

 Navy

 Green

 White

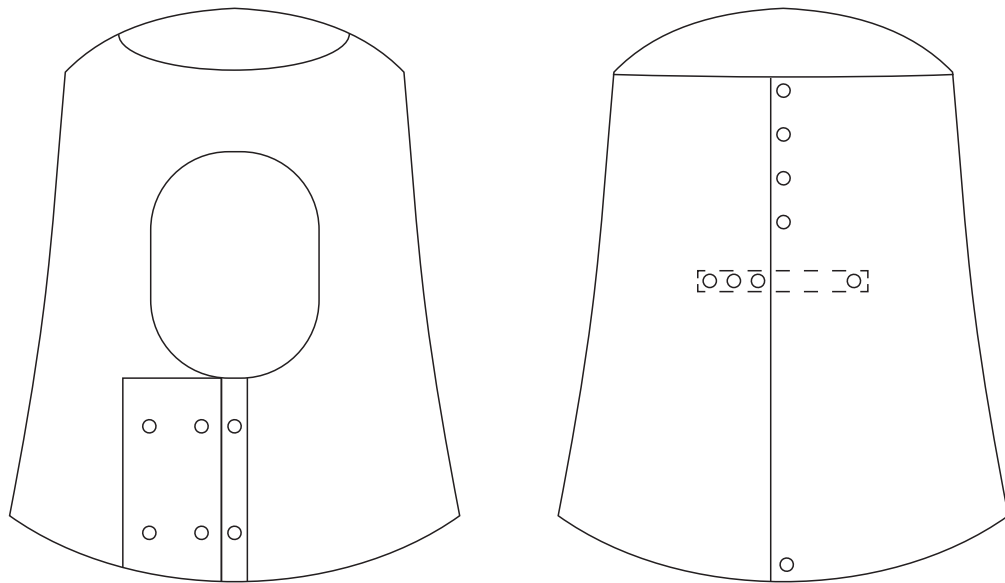

SIZING INFORMATION

Reference	XSM	SML	MED	LGE	XLG	XXL	Tolerances
Crown Diameter	15.5	16.0	16.5	17.0	17.5	18.0	+/-1.0
Fr'Length (stud post)	18.0	18.0	18.0	18.0	18.0	18.0	+/-1.0
Back Lenght	39.0	39.0	39.0	39.0	39.0	39.0	+/-1.0
Fr'Length (forehead)	7.0	7.0	7.0	7.0	7.0	7.0	+/-1.0

WOVEN BARCODE LABELS

Woven barcode label positioned inside right approx 5cm up and 1cm in from face.
Printed size/traceability label sewn into the back seam.